GEA Mission

The Global Electronics Association promotes industry growth and strengthens supply chain resilience.

About IPC Standards by Global Electronics Association

IPC standards and publications by Global Electronics Association are designed to serve the public interest through eliminating misunderstandings between manufacturers and purchasers, facilitating interchangeability and improvement of products, and assisting the purchaser in selecting and obtaining with minimum delay the proper product for their particular need. Existence of such standards and publications shall not in any respect preclude any entity from manufacturing or selling products not conforming to such standards and publications, nor shall the existence of such standards and publications preclude their voluntary use.

IPC standards and publications by Global Electronics Association are approved by committees without regard to whether the standards or publications may involve patents on articles, materials or processes. By such action, Global Electronics Association does not assume any liability to any patent owner, nor does Global Electronics Association assume any obligation whatsoever to parties adopting a standard or publication. Users are wholly responsible for protecting themselves against all claims of liabilities for patent infringement.

Global Electronics Association Position Statement on Specification Revision Change

The use and implementation of IPC standards and publications by Global Electronics Association are voluntary and part of a relationship entered into by customer and supplier. When a standard or publication is revised or amended, the use of the latest revision or amendment as part of an existing relationship is not automatic unless required by the contract. Global Electronics Association recommends the use of the latest revision or amendment.

Standards Improvement Recommendations

Global Electronics Association welcomes comments for improvements to any standard in its library. All comments will be provided to the appropriate committee.

If a change to technical content is requested, data to support the request is recommended. Technical comments to include new technologies or make changes to published requirements should be accompanied by technical data to support the request. This information will be used by the committee to resolve the comment.

To submit your comments, visit the Status of Standardization page at www.electronics.org/status.



IPC-2223F

Sectional Design Standard for Flexible/Rigid-Flexible Printed Boards

If a conflict occurs between the English language and translated versions of this document, the English version will take precedence.

Developed by the Flexible Circuits Design Subcommittee (D-11) of the Flexible Circuits Committee (D-10) of Global Electronics Association

Global Electronics Association Standards and Artificial Intelligence (AI) Statement

Global Electronics Association is the trading name of IPC International, Inc., which owns the copyright to all IPC Standards and other IPC materials.

The Global Electronics Association explicitly prohibits:

- The integration or transfer of any data whether in the form of IPC books, standards, metadata, or other formats - into AI engines or algorithms by any person or entity, including authorized distributors and their end users.
- Activities involving data harvesting, text and data mining, enrichment, or the creation of derivative works based on this data, including the use of automated data collection methods or artificial intelligence.

Any breach of these provisions is considered a copyright infringement unless expressly authorized in advance in writing by the Global Electronics Association.

Supersedes:
IPC-2223E - January 2020

Users of this publication are encouraged to participate in the development of future revisions.

Contact:

Global Electronics Association
3000 Lakeside Drive, Suite 105N
Bannockburn, Illinois
60015-1249
Tel 847 615.7100
Fax 847 615.7105

Acknowledgment

Any document involving a complex technology draws material from a vast number of sources across many continents. While the principal members of the Flexible Circuits Design Subcommittee (D-11) are shown below, it is not possible to include all of those who assisted in the evolution of this standard. To each of them, the members of Global Electronics Association extend their gratitude.

| Flexible Circuits Committee | Flexible Circuits Design Subcommittee | Technical Liaison of the IPC Board of Directors |
|--|---|--|
| Chair Nick Koop TTM Technologies, Inc. | Chair Mark Finstad Flexible Circuit Technologies, Inc. | Bob Neves Reliability Assessment Solutions Inc. |
| Vice Chair Mark Finstad Flexible Circuit Technologies, Inc. | Vice Chair Steven Bowles Lockheed Martin Missiles and Fire Control | |

Members of the Members of the Flexible Circuits Design Subcommittee

| | | |
|---|---|---|
| Buoniconti, Ralph Sabic | Korf, Dana Korf Consultancy LLC | Price, Nicholas Anduril Industries |
| Caputa, David Joseph Lockheed Martin Corporation | Kusiak, Kevin Lockheed Martin Space Systems Company | Romont, Thomas IFTEC |
| Clark, Christopher Flexible Circuit Technologies, Inc. | Lee, Minsu Korea Package Integration Association | Rowe, Dave Sheldahl Flexible Technologies, Inc. |
| Di Maio, Francesco Francesco Di Maio Consulting | Lehmicke, Mike All Flex Solutions | Roy, Steven D. Roy Design and Manufacturing Service |
| Fox, William Lockheed Martin Missile & Fire Control | Loew, Dan L3Harris | Senese, Tony R. Panasonic Industrial Devices Sales Company of America (PIDSA) |
| Gandhi, Mahendra S. Northrop Grumman Space Systems | MacFadden, Todd Bose Corporation | Shubrooks, Jeff Raytheon Company |
| Glaze, Timothy Louis AdvancedPCB - Anaheim | Markel, Nicholas Lockheed Martin | Stevens, Brian Collins Aerospace |
| Gough, Paul M Honeywell Aerospace | Mertens, Matthew Flexible Circuits Inc. | Tlaxcalteca, Kevin Northrop Grumman Space Systems |
| Jones, Roxanne Career Technologies | Murray, Steven Northrop Grumman Corporation | Toone, Bradley E. L3 Harris Technologies Communication Systems - West |
| Kahn, Haberly B Lockheed Martin Corporation | Norder, Naji National Instruments | Welzel, Udo Robert Bosch GmbH |
| Keeney, Allen Johns Hopkins University | Oliver, Glenn Lockheed Martin Missiles & Fire Control | |
| Kennedy, Aaron Summit Interconnect - Anaheim | Partida, Gerry Summit Interconnect - Anaheim | |
| Koop, Nick S. TTM Technologies | | |

Table of Contents

| | | | | | |
|------------|---|---|------------|--|----|
| 1 | SCOPE | 1 | 4.3.1.2 | Dynamic Flex Applications | 9 |
| 1.1 | Purpose | 1 | 4.3.1.3 | Hole Plating | 9 |
| 1.2 | Classification of Products | 1 | 4.3.1.4 | Selective Plating Requirements..... | 9 |
| 1.2.1 | Printed Board Type | 1 | 4.3.2 | Nickel Plating | 10 |
| 1.2.2 | Installation Uses | 3 | 4.3.3 | Tin-Lead Plating..... | 10 |
| 1.3 | Measurement Units | 4 | 4.3.4 | Solder Coating..... | 10 |
| 1.4 | Definition of Requirements | 4 | 4.3.5 | Other Metallic Coatings..... | 11 |
| 1.5 | Conflict | 4 | 4.3.6 | Electronic Component Materials (Buried Resistors and Capacitors) | 11 |
| 2 | APPLICABLE DOCUMENTS | 4 | 4.3.7 | Conductive Coatings for Shielding | 11 |
| 2.1 | IPC | 4 | 4.4 | Organic Protective Coatings | 11 |
| 2.2 | Joint Industry Standards | 4 | 4.4.1 | Solder Mask | 11 |
| 3 | GENERAL REQUIREMENTS | 5 | 4.4.2 | Conformal Coating | 11 |
| 3.1 | Design Modeling | 5 | 4.5 | Marking and Legend | 11 |
| 3.2 | Design Layout | 5 | 5 | MECHANICAL AND PHYSICAL PROPERTIES | 11 |
| 3.2.1 | Mechanical Layout Efficiency (Consider Final Panelization) | 5 | 5.1 | Fabrication Requirements | 11 |
| 3.2.2 | Fabrication Drawing Recommendations | 5 | 5.1.1 | Bare Printed Board Fabrication..... | 11 |
| 3.3 | Schematic | 5 | 5.1.2 | Roll to Roll Fabrication | 11 |
| 3.4 | Test Requirement Considerations | 6 | 5.2 | Product/Printed Board Configuration | 11 |
| 3.4.1 | Environmental..... | 6 | 5.2.1 | Circuit Profile (Outline)..... | 12 |
| 3.4.2 | Mechanical/Flexural | 6 | 5.2.1.1 | Minimum Radius (Flexible Sections)..... | 12 |
| 4 | MATERIALS | 6 | 5.2.1.2 | Hole to Edge Distance (Flexible and Rigid sections)..... | 13 |
| 4.1 | Material Selection | 6 | 5.2.1.3 | Hole to Edge Distance (Rigid-to-Flex Transition Section)..... | 13 |
| 4.1.1 | Material Options..... | 7 | 5.2.1.4 | Counterbores and Countersinks | 13 |
| 4.2 | Dielectric Materials (Including Prepreg and Adhesives) | 7 | 5.2.1.5 | Variable Thicknesses..... | 13 |
| 4.2.1 | Preimpregnated Bonding Material (Prepreg)..... | 7 | 5.2.1.6 | Strain Relief..... | 13 |
| 4.2.2 | Adhesives (Liquid) | 7 | 5.2.2 | Rigid Area Considerations | 13 |
| 4.2.3 | Flexible Adhesive Bonding Films (Cast Adhesive or Bondply)..... | 7 | 5.2.2.1 | Bow and Twist..... | 13 |
| 4.2.4 | Conductive Anisotropic Adhesives | 7 | 5.2.2.2 | PTH Reliability..... | 13 |
| 4.2.4.1 | Flexible Metal Clad Dielectrics (Flexible Substrate Materials)..... | 7 | 5.2.2.3 | PTHs to Rigid-Flex Interface..... | 14 |
| 4.2.4.2 | Rigid Metal Clad Laminate Materials..... | 8 | 5.2.2.4 | Additional Dielectric Material..... | 14 |
| 4.2.5 | Cover Materials | 8 | 5.2.3 | Flexible Areas | 14 |
| 4.2.5.1 | Coverlay | 8 | 5.2.3.1 | Flexible Area Considerations..... | 14 |
| 4.2.5.2 | Coverfilm | 8 | 5.2.3.2 | Bend Area Conductor Considerations..... | 15 |
| 4.2.5.3 | Covercoat | 8 | 5.2.3.3 | Estimation of Minimum Bending for Flexible Circuits with Coverlay | 16 |
| 4.3 | Conductive Materials (Surface Finishes) | 9 | 5.2.4 | Performing Bend | 17 |
| 4.3.1 | Electrolytic Copper Plating | 9 | 5.2.4.1 | Bends or Folds (Greater than 90°)..... | 18 |
| 4.3.1.1 | Flex-to-Install Applications | 9 | 5.2.4.2 | Flex-to-Install Radii (Two Layers or Less)..... | 18 |
| | | | 5.2.4.3 | Bonded Multilayer Bending..... | 19 |

| | | | | | |
|------------|---|----|-------------|---|----|
| 5.2.5 | Differential Lengths..... | 19 | 7 | THERMAL MANAGEMENT..... | 29 |
| 5.2.5.1 | Differential Lengths (Flexible Printed Boards)... | 19 | 8 | COMPONENT AND ASSEMBLY ISSUES..... | 29 |
| 5.2.5.1.1 | Calculation | 20 | 8.1 | General Placement Requirements | 29 |
| 5.2.5.2 | Differential Lengths (Multilayer and Rigid-Flex) | 21 | 8.2 | Standard Surface Mount Requirements | 29 |
| 5.2.5.3 | Staggered Flexible Layer Bands (Multilayer and Rigid Flex) | 21 | 8.3 | Lands for Surface Mounting | 29 |
| 5.2.6 | Shielding | 22 | 8.4 | Constraints on Mounting to Flexible Sections.... | 29 |
| 5.2.7 | Ground/Power Plane | 22 | 8.5 | Interfacial Connections..... | 29 |
| 5.2.8 | Stiffeners and Heat Sinks | 23 | 8.6 | Offset Lands..... | 29 |
| 5.2.9 | Strain Relief Fillet Guidelines for Flexible and Rigid-Flex Printed Boards | 23 | 9 | HOLES/INTERCONNECTIONS | 30 |
| 5.3 | Assembly Requirements | 24 | 9.1 | General Requirements for Lands with Holes | 30 |
| 5.3.1 | Mechanical Considerations..... | 24 | 9.1.1 | Land Requirements | 30 |
| 5.3.2 | Array Sub-Pallets for Flexible and Rigid Printed Boards..... | 24 | 9.1.2 | Annular Ring Requirements..... | 30 |
| 5.3.3 | Single Part Sub-Pallets..... | 24 | 9.1.3 | Eyelet or Standoff Land Area Considerations | 30 |
| 5.3.4 | Non-Palletized Flexible and Rigid-Flex Printed Boards..... | 24 | 9.1.4 | Land Size for Non-Plated Component Holes.... | 30 |
| 5.3.5 | Moisture | 24 | 9.1.5 | Land Size for Plated-Through Component Holes. | 30 |
| 5.3.6 | Infrared Preheats and Reflow..... | 25 | 9.1.6 | Thermal Relief in Conductor Planes..... | 30 |
| 5.3.7 | Adhesive T _g | 25 | 9.1.7 | Nonfunctional Lands..... | 30 |
| 5.4 | Dimensioning Systems..... | 25 | 9.1.8 | Land-to-Conductor Transition..... | 31 |
| 5.4.1 | Datum Features..... | 25 | 9.1.9 | Unsupported Edge Conductors/Fingers | 32 |
| 6 | ELECTRICAL PROPERTIES | 26 | 9.1.9.1 | Processes..... | 34 |
| 6.1 | Electrical Considerations..... | 26 | 9.1.9.2 | Design Options | 36 |
| 6.2 | Impedance and Capacitance Control | 26 | 9.1.9.3 | Mounting Flex to a Printed Board | 37 |
| 6.2.1 | Impedance Modeling Software | 26 | 9.2 | Holes | 37 |
| 6.2.2 | Material Thickness and Stack up | 26 | 9.2.1 | Unsupported (Non-plated) Component Holes | 37 |
| 6.2.2.1 | Dielectric Constant (Dk, Er)..... | 26 | 9.2.2 | Plated Component Holes..... | 37 |
| 6.2.2.2 | Cut-back Coverlay/Bondply/Adhesive..... | 26 | 9.2.2.1 | Etchback | 37 |
| 6.2.3 | Conductor Pitch | 27 | 9.2.3 | Copper Filled Vias | 37 |
| 6.2.4 | Narrow Conductors | 27 | 9.2.3.1 | Microvia Stacking | 37 |
| 6.2.4.1 | TDR Measurement Considerations for Narrow Conductors | 27 | 9.3 | Cover Material Access Openings | 38 |
| 6.2.5 | Differential Impedance..... | 27 | 9.3.1 | Coverlay Access, SMT..... | 38 |
| 6.2.6 | Unbonded Flexible Impedance Controlled Layers (“Loose-leaf layers”) | 28 | 9.3.2 | Coverlay Access, Holes | 38 |
| 6.2.7 | Modifications to Shield Layers | 28 | 9.3.3 | Coverlay Access Spacing | 38 |
| 6.2.7.1 | Cross Hatching | 28 | 9.3.4 | Land Access/Exposed Lands | 39 |
| 6.2.7.2 | Thick-Film Conductor Shielding (Silver Epoxy)..... | 28 | 9.3.5 | Type 1 Land Access, Opposite Sides..... | 39 |
| 6.2.7.3 | Shielding Film..... | 28 | 10 | CONDUCTORS | 39 |
| 6.2.8 | Dielectric Constant Changes Over Frequency.... | 29 | 10.1 | Conductor Characteristics..... | 39 |
| | | | 10.1.1 | Conductor Routing | 39 |
| | | | 10.1.2 | Conductor Edge Spacing..... | 40 |
| | | | 10.2 | Land Characteristics..... | 40 |
| | | | 10.3 | Large Conductive Areas | 40 |
| | | | 11 | DOCUMENTATION | 40 |

12 QUALITY ASSURANCE 40

Appendix A Design Tutorial 41

A.1 Flexing and Forming 41

A.2 Material Selection Guidelines 41

A.3 Stress Concentration Features (Stress Risers) 42

A.3.1 Dual Row Zero Insertion Force (ZIF) Connectors 42

A.4 Overall Size & Shape 43

A.5 Allowances 43

A.6 Symmetry 43

A.7 Length 43

A.8 Rigid Areas (Types 1, 2 and 3) 43

A.8.1 Rigid Areas (Type 4) 43

A.9 Flexible Areas 43

A.10 Banding 44

A.11 Symmetrical Lay Ups 44

A.12 Access Openings in Coverlay for SMT 44

A.13 Forms of Plating 44

A.13.1 Panel Plating 44

A.13.2 Pattern Plating 44

A.13.3 Button Plating (Pads Only) 45

A.13.4 Trade-Offs and Applications 46

A.14 Reference Literature 46

Figures

Figure 1-1 Type 1 Single-sided Flexible Printed Board - Adhesive Substrate Construction 1

Figure 1-2 Type 1 Single-sided Flexible Printed Board - Adhesiveless Substrate Construction 1

Figure 1-3 Type 2 Double-sided Flexible Printed Board - Adhesive Substrate Construction 2

Figure 1-4 Type 2 Double-sided Flexible Printed Board - Adhesiveless Substrate Construction 2

Figure 1-5 Type 3 Multilayer Flexible Printed Board - Adhesive Substrate Construction 2

Figure 1-6 Type 3 Multilayer Flexible Printed Board - Adhesiveless Substrate Construction 2

Figure 1-7 Type 4 Rigid-flex Printed Board - Adhesiveless Substrate Construction 3

Figure 1-8 Type 5 Flexible or Rigid-flex Printed Board without PTHs - Adhesive Substrate Construction 3

Figure 1-9 Type 5 Flexible or Rigid-flex Printed Board without PTHs - Adhesiveless Substrate Construction 3

Figure 3-1 Dimensional Modeling 5

Figure 3-2 Final Panelization 5

Figure 4-1 Flexible Cross-Sectional Construction Examples 6

Figure 4-2 Unbonded Flex Cross-sectional Construction of Rigid Flex 6

Figure 4-3 Selective Plating for Adhesiveless Substrate Applications 10

Figure 4-4 Selective Plating for Adhesive Substrate Applications 10

Figure 5-1 Circuits Nested On a Panel 12

Figure 5-2 Special Flexible Printed Board Features 12

Figure 5-3 Cutout with a Drilled Hole 12

Figure 5-4 Reinforcement Patch for Flex Area 13

Figure 5-5 Slits and Slots 13

Figure 5-6 Spacing of PTH from Rigid to Flex Interface ... 14

Figure 5-7 Reduced Bend Radii 15

Figure 5-8 Conductors in Bend Areas 16

Figure 5-9 Bend/Crease Areas Center Lines 16

Figure 5-10 Neutral Axis Ideal Construction 16

Figure 5-11 Definition of Bend Ratio 17

Figure 5-12 Irregular Folds 18

Figure 5-13 Differential Printed Board Lengths 19

Figure 5-14 Differential Printed Board Lengths, Rigid-Flex 19

Figure 5-15 Bookbinder 21

Figure 5-16 Staggered Flexible Layer Bands 21

Figure 5-17 Staggered Flexible Layer Bands 22

Figure 5-18 Typical Example of Copper Removal for Flexible Shielding 22

Figure 5-19 Stiffener Thickness Preferred in Order to Apply Strain Relief Fillet 23

Figure 5-20 Strain Relief 23

Figure 5-21 Rigid Rails for Single Part Sub-Pallets 24

Figure 5-22 Establishing Datums 25

Figure 6-1 Adjustment to Dielectric Thickness between Rigid and Flexible Regions 26

Figure 6-2 Conductor Pitch for Differential Pairs 27

Figure 6-3 TDR Waveform for Type 2 Flexible Printed Board 27

Figure 6-4 Buckling of Unbonded Flexible Layers 28

Figure 6-5 Cross Hatching 28

Figure 9-1 Conductor to Land Transitions 30

Figure 9-2 Sculptured, Straight, Tapered Fingers 32

Figure 9-3 Sculptured, Formed for Surface Mount 32

Figure 9-4 Sculptured, Formed for Through-hole 32

| | | Tables | |
|-------------|---|---------------|--|
| Figure 9-5 | Straight Fingers for Lap Soldering to Printed Board 32 | Table 4-1 | Characteristics of Typical Flexible Dielectrics ... 8 |
| Figure 9-6 | Adhesive Squeeze Out Where Fingers Exit Insulation 34 | Table 4-2 | Minimum Average Copper Thickness, mm [in] ... 9 |
| Figure 9-7 | Laser Ablated Window..... 34 | Table 9-1 | Minimum Standard Fabrication Allowance for Interconnection Lands, mm [in]..... 30 |
| Figure 9-8 | Broken Fingers Resulting from Poor Handling..... 35 | Table 9-2 | Nonfunctional Land Considerations 31 |
| Figure 9-9 | Fingers Connected with a Foil Buss Bar..... 35 | Table 9-3 | Typical Foil Options for Designing for Flex Circuits with Unsupported Fingers 33 |
| Figure 9-10 | Insulator Buss Bar with Notched Fingers 35 | Table 9-4 | Common Brazed Finger Options 37 |
| Figure 9-11 | Fingers Attached to a Support Bar..... 35 | Table A-1 | Benefits and Drawbacks of Panel, Pattern and Button (Pads Only) Plating 46 |
| Figure 9-12 | Staggered Base/Coverlay Edges Used to Reduce Stress Points..... 36 | | |
| Figure 9-13 | Sculptured Flex Showing the Foil Thickness Transition 36 | | |
| Figure 9-14 | Fingers Brazed to Circuit Lands..... 37 | | |
| Figure 9-15 | Bonding of Unsupported Fingers to Printed Board with Reinforcement 37 | | |
| Figure 9-16 | Coverlay Access Openings and Exposed SMT Lands 38 | | |
| Figure 9-17 | Coverlay Access Opening for Unsupported Lands 38 | | |
| Figure 9-18 | Coverlay Access Openings and Exposed Supported Lands 39 | | |
| Figure 10-1 | Conductor Routing, Rigid-Flex Transition..... 39 | | |
| Figure A-1 | Single Row ZIF Style Printed Board Contact Area 42 | | |
| Figure A-2 | Dual Row ZIF Style Printed Board Contact Area 42 | | |
| Figure A-3 | Cross-sectional example of Panel, Pattern and Button Plating..... 45 | | |
| Figure A-4 | Button Plating of both Via Lands and Adjacent SMT Lands 45 | | |

Sectional Design Standard for Flexible/Rigid-Flexible Printed Boards

1 SCOPE

This standard establishes the specific requirements for the design of flexible and rigid-flexible printed board applications and its forms of component mounting and interconnecting structures. The flexible materials used in the structures are comprised of insulating films, reinforced and/or non-reinforced, dielectric in combination with metallic materials. These interconnecting boards may contain single, double, multilayer, or multiple conductive layers and can be comprised wholly of flex or a combination of both flex and rigid.

1.1 Purpose The requirements contained herein are intended to establish specific design details that **shall** be used in conjunction with IPC-2221 and may also be used in conjunction with IPC-2222 for the rigid sections of rigid-flex circuits and IPC-2228 for RF/Microwave applications.

1.2 Classification of Products Performance Classification, printed board type and use of products **shall** be in accordance with IPC-2221 and as stated in 1.2.1 and 1.2.2.

1.2.1 Printed Board Type This standard provides design information for different flexible and rigid-flex printed board types. Printed board types are classified as:

Type 1 Single-sided flexible printed board containing one conductive layer, with or without stiffener, and constructed using an adhesive or adhesiveless substrate (see Figure 1-1 and Figure 1-2).

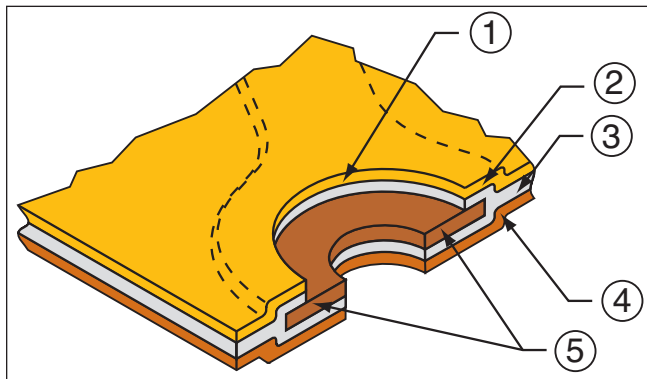

Figure 1-1 Type 1 Single-sided Flexible Printed Board - Adhesive Substrate Construction

Note 1. Access Hole.

Note 2. Coverlay.

Note 3. Adhesive.

Note 4. Substrate.

Note 5. Copper Pad.

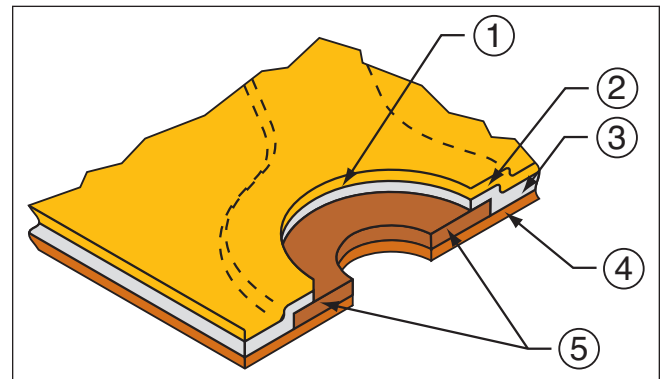

Figure 1-2 Type 1 Single-sided Flexible Printed Board - Adhesiveless Substrate Construction

Note 1. Access Hole.

Note 2. Coverlay.

Note 3. Adhesive.

Note 4. Adhesiveless substrate.

Note 5. Copper Pad.